

MOD SERIES

EXTERNAL ROBOTO ROLLER BURNISHING TOOLS



For external diameters from $\varnothing 1.5$ to $\varnothing 110$ mm

Unlimited working length with hollow shank

MF- Machine Feeding Tools for straight shafts

SF- Self Feeding Tools for straight shafts

BMF - Machine Feeding Tools for stepped shafts

AVAILABLE FROM STOCK



MOD - EXTERNAL ROBUTO Ø3 - Ø14 mm



UNLIMITED ROLLING LENGTH-
WITH HOLLOW SHANK

TOOL DIA. (mm)	Dia. Setting Range (mm)			Burnishing Roller			
	Straight Shaft		Stepped Shaft	Straight Shaft		Stepped Shaft	
	Self Feeding	Machine Feeding	Machine Feeding	Dia.	Qty.	Dia.	Qty.
3.00							
3.50							
4.00							
4.50							
5.00							
5.50	+0.10	+0.10	+0.00	5.50	3	5.50	3
6.00	-0.40	-0.30	-0.15				
6.50							
7.00							
7.50							
8.00							
8.50							
9.00							
9.50							
10.00	+0.10	+0.10	+0.00	5.50	4	5.50	4
10.50	-0.40	-0.30	-0.15				
11.00							
11.50							
12.00							
12.50	+0.10	+0.10	+0.00	5.50	5	5.50	5
13.00	-0.40	-0.30	-0.15				
13.50							
14.00							

SHANK TYPE

MT 2 SHANK
(Max. 78mm Rolling Length)



Hollow Cylindrical Shank
Ø25-Ø16 x 60 mm
(Unlimited Rolling Length)



DESIGN VERSION



machine feeding
type for straight
shafts



self feeding
type for straight
shafts



machine feeding
type for stepped
shafts

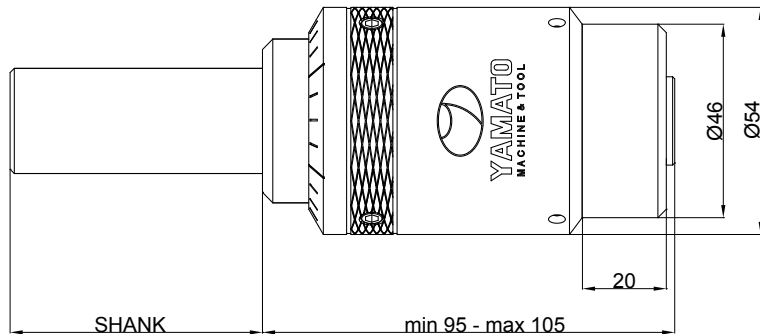

MOD - EXTERNAL ROBU TO

Ø14.5 - Ø25 mm

TOOL DIA. (mm)	Dia. Setting Range (mm)			Burnishing Roller			
	Straight Shaft		Stepped Shaft	Straight Shaft		Stepped Shaft	
	Self Feeding	Machine Feeding	Machine Feeding	Dia.	Qty.	Dia.	Qty.
14.50							
15.00							
15.50							
16.00	+0.10	+0.10	+0.00	5.50	5	5.50	5
16.50	-0.40	-0.30	-0.15				
17.00							
17.50							
18.00							
18.50							
19.00							
19.50	+0.10	+0.10	+0.00	5.50	6	5.50	6
20.00	-0.40	-0.30	-0.15				
20.50							
21.00							
21.50							
22.00							
22.50							
23.00	+0.10	+0.10	+0.00	5.50	7	5.50	7
23.50	-0.40	-0.30	-0.15				
24.00							
24.50							
25.00							

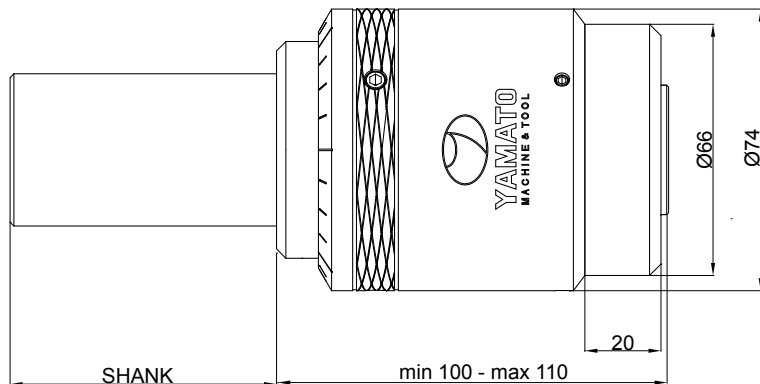

UNLIMITED ROLLING LENGTH
WITH HOLLOW SHANK

SHANK TYPE

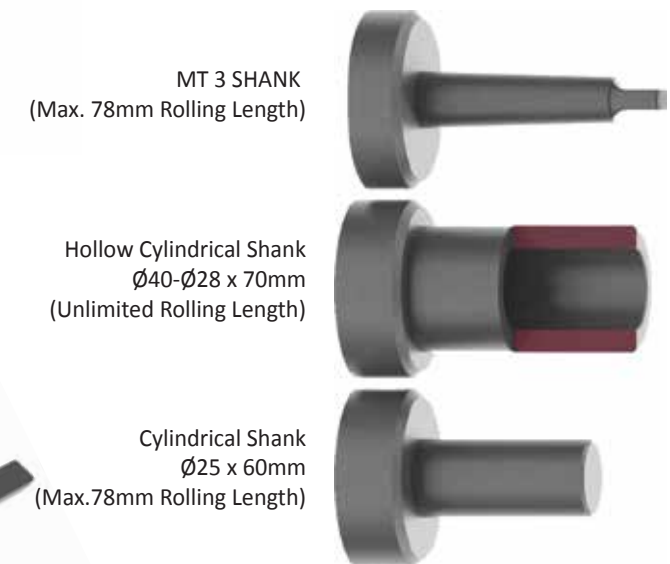

DESIGN VERSION

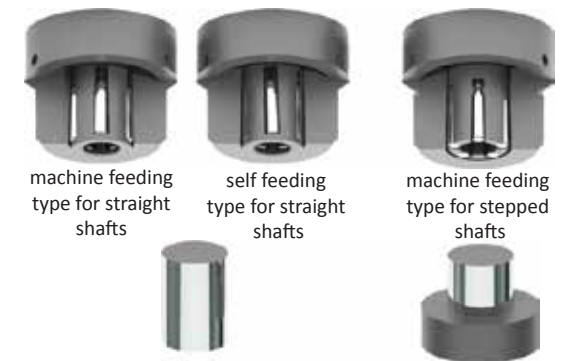

MOD - EXTERNAL ROBUTO

Ø25.5 - Ø50 mm

TOOL DIA. (mm)	Dia. Setting Range (mm)			Burnishing Roller			
	Straight Shaft		Stepped Shaft	Straight Shaft		Stepped Shaft	
	Self Feeding	Machine Feeding	Machine Feeding	Dia.	Qty.	Dia.	Qty.
25.50							
28.00							
30.00	+0.10	+0.10	+0.00	7.85	7	7.85	7
32.00	-0.50	-0.40	-0.15				
35.00							
38.00							
39.00							
40.00	+0.10	+0.10	+0.00	7.85	9	7.85	9
45.00	-0.50	-0.40	-0.15				
50.00							

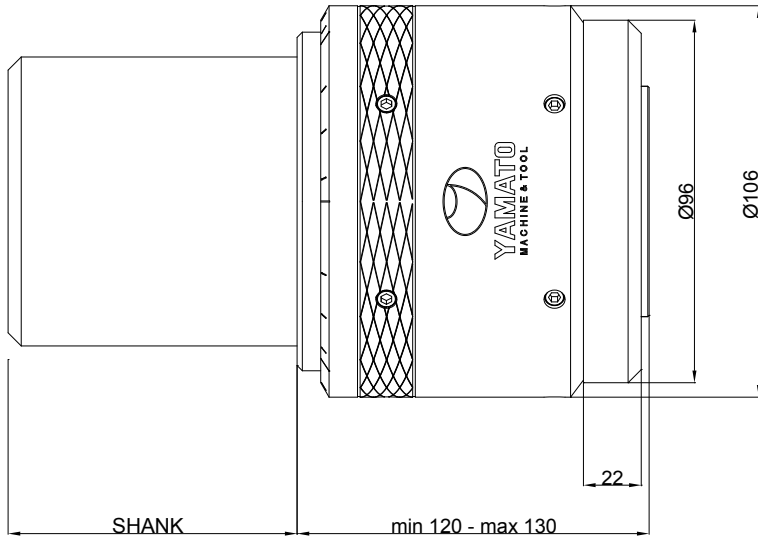

UNLIMITED ROLLING LENGTH
WITH HOLLOW SHANK

SHANK TYPE

MT 4 SHANK
(Max. 105mm Rolling Length)



Hollow Cylindrical Shank
Ø80-Ø52 x 90mm
(Unlimited Rolling Length)



Cylindrical Shank
Ø40 x 70 mm
(Max. 105mm Rolling Length)



DESIGN VERSION



machine feeding
type for straight
shafts



self feeding
type for straight
shafts



machine feeding
type for stepped
shafts



MOD - EXTERNAL ROBU TO

Ø50.5 - Ø85 mm

TOOL DIA. (mm)	Dia. Setting Range (mm)			Burnishing Roller			
	Straight Shaft		Stepped Shaft	Straight Shaft		Stepped Shaft	
	Self Feeding	Machine Feeding	Machine Feeding	Dia.	Qty.	Dia.	Qty.
51.00							
55.00							
60.00	+0.10	+0.10	+0.00	7.85	11	7.85	11
63.00	-0.50	-0.40	-0.15				
65.00							
69.00							
70.00							
75.00	+0.10	+0.10	+0.00	7.85	13	7.85	13
80.00	-0.50	-0.40	-0.15				
85.00							

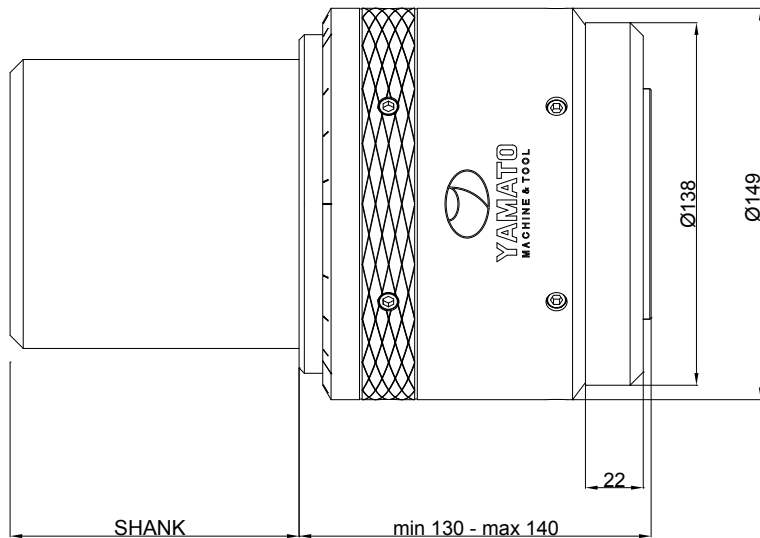

UNLIMITED ROLLING LENGTH
WITH HOLLOW SHANK

SHANK TYPE

MT 4 SHANK
(Max. 120mm Rolling Length)



Hollow Cylindrical Shank
Ø110-Ø88 x 110mm
(Unlimited Rolling Length)



Cylindrical Shank
Ø40 x 70 mm
(Max. 120mm Rolling Length)



DESIGN VERSION



machine feeding
type for straight
shafts



self feeding
type for straight
shafts



machine feeding
type for stepped
shafts



MOD - EXTERNAL ROBUTO

Ø85.5 - Ø110 mm

TOOL DIA. (mm)	Dia. Setting Range (mm)			Burnishing Roller			
	Straight Shaft		Stepped Shaft	Straight Shaft		Stepped Shaft	
	Self Feeding	Machine Feeding	Machine Feeding	Dia.	Qty.	Dia.	Qty.
86.00	+0.10	+0.10	+0.00	13.50	9	13.50	9
90.00	-0.50	-0.40	-0.15				
95.00							
96.00	+0.10	+0.10	+0.00	13.50	11	13.50	11
100.00	-0.50	-0.40	-0.15				
105.00							
106.00	+0.10	+0.10	+0.00	13.50	13	13.50	13
110.00	-0.50	-0.40	-0.15				

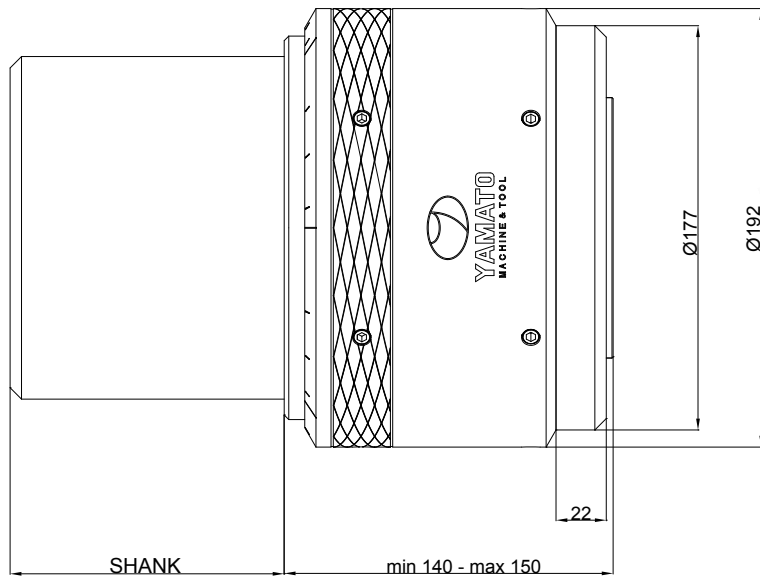

UNLIMITED ROLLING LENGTH
WITH HOLLOW SHANK

SHANK TYPE

MT 5 SHANK
(Max. 127mm Rolling Length)



Hollow Cylindrical Shank
Ø150-Ø113 x 120mm
(Unlimited Rolling Length)



Cylindrical Shank
Ø50 x 80 mm
(Max. 127mm Rolling Length)

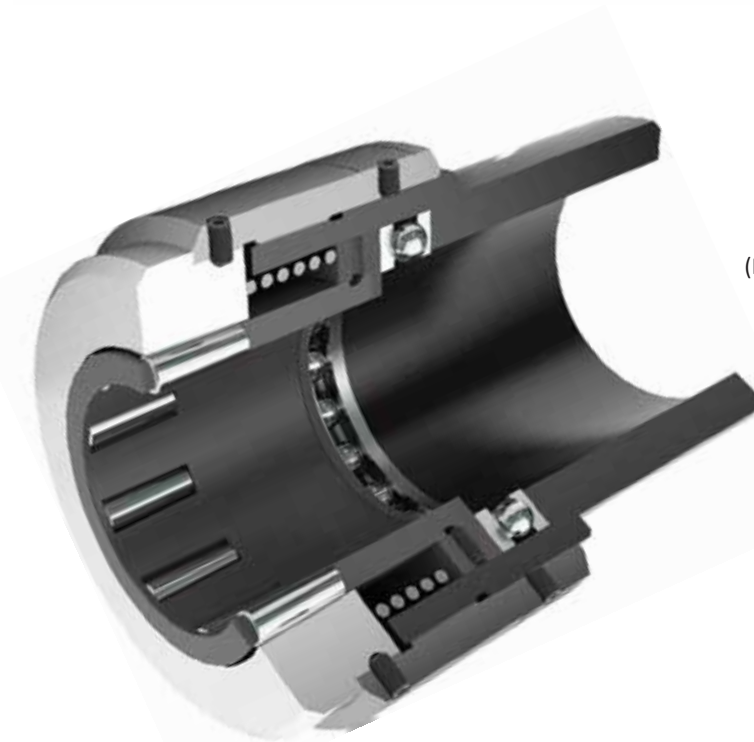

DESIGN VERSION



machine feeding
type for straight
shafts



self feeding
type for straight
shafts



machine feeding
type for stepped
shafts

